

OSI-RE Smoke Imaging Linear Beam Detector (Projected Beam Type) - Conventional Installation Guide



OSI-RE

Intellectual Property and Copyright

This document includes registered and unregistered trademarks. All trademarks displayed are the trademarks of their respective owners. Your use of this document does not constitute or create a license or any other right to use the name and/or trademark and/or label.

This document is subject to copyright owned by HPSS (Honeywell Products & Solutions Sarl). You agree not to copy, communicate to the public, adapt, distribute, transfer, sell, modify or publish any contents of this document without the express prior written consent of Xtralis.

Disclaimer

The contents of this document is provided on an “as is” basis. No representation or warranty (either express or implied) is made as to the completeness, accuracy or reliability of the contents of this document. The manufacturer reserves the right to change designs or specifications without obligation and without further notice. Except as otherwise provided, all warranties, express or implied, including without limitation any implied warranties of merchantability and fitness for a particular purpose are expressly excluded.

General Warning

This product must only be installed, configured and used strictly in accordance with the General Terms and Conditions, Warranty, User Manual, Third Party Licenses, and product documents available from Xtralis website (www.xtralis.com). All proper health and safety precautions must be taken during the installation, commissioning and maintenance of the product. The system should not be connected to a power source until all the components have been installed. Proper safety precautions must be taken during tests and maintenance of the products when these are still connected to the power source. Failure to do so or tampering with the electronics inside the products can result in an electric shock causing injury or death and may cause equipment damage. Xtralis is not responsible and cannot be held accountable for any liability that may arise due to improper use of the equipment and/or failure to take proper precautions. Only persons trained through an Xtralis accredited training course can install, test and maintain the system.

Critical Product Security

Open Source Software

This product contains open source software provided by third parties. It does not necessarily use all of the third party software components. Go to <http://www.security.honeywell.com/opensource/> for a detailed list of the third party software used and the associated open source license agreement(s).

Firmware Updates

This device supports firmware upgrades via its USB port. When performing a firmware update the new firmware update file should be downloaded from the Xtralis website and saved to a USB memory device that has had all of its content removed.

Approved firmware version: S05-0089-006.

Device and System Security

Before installing this product ensure that the two security seals on the packaging are unbroken and the product has not been tampered with since leaving the factory. Do not install this product if there are any indications of tampering. If there are any signs of tampering the product should be returned to the point of purchase.

It is the responsibility of the system owner to ensure that all system components, i.e. devices, panels, wiring etc., are adequately protected to avoid tampering of the system that could result in information disclosure, spoofing, and integrity violation.

This device utilizes Secure Boot to validate the device’s software using a hardware root of trust and cryptographic signatures. If the software cannot be validated the device will generate a trouble condition in the system.

Liability

You agree to install, configure and use the products strictly in accordance with the User Manual and product documents available from Xtralis.

Xtralis is not liable to you or any other person for incidental, indirect, or consequential loss, expense or damages of any kind including without limitation, loss of business, loss of profits or loss of data arising out of your use of the products. Without limiting this general disclaimer the following specific warnings and disclaimers also apply:

Fitness for Purpose

You agree that you have been provided with a reasonable opportunity to appraise the products and have made your own independent assessment of the fitness or suitability of the products for your purpose. You acknowledge that you have not relied on any oral or written information, representation or advice given by or on behalf of Xtralis or its representatives.

Total Liability

To the fullest extent permitted by law that any limitation or exclusion cannot apply, the total liability of Xtralis in relation to the products is limited to:

- i. in the case of services, the cost of having the services supplied again; or
- ii. in the case of goods, the lowest cost of replacing the goods, acquiring equivalent goods or having the goods repaired.

Indemnification

You agree to fully indemnify and hold Xtralis harmless for any claim, cost, demand or damage (including legal costs on a full indemnity basis) incurred or which may be incurred arising from your use of the products.

Miscellaneous

If any provision outlined above is found to be invalid or unenforceable by a court of law, such invalidity or unenforceability will not affect the remainder which will continue in full force and effect. All rights not expressly granted are reserved.

Document Conventions

The following typographic conventions are used in this document:

Convention	Description
<i>Italics</i>	Used to denote: references to other parts of this document or other documents. Used for the result of an action.

Contact Us

www.xtralis.com

Codes and Standards Information for Smoke Detection

It is strongly recommended that this document is read in conjunction with the appropriate local codes and standards for smoke detection and electrical connections. This document contains generic product information and some sections may not comply with all local codes and standards. In these cases, the local codes and standards must take precedence. The information below was correct at time of printing but may now be out of date. Check with your local codes, standards and listings for the current restrictions.

Honeywell Products & Solutions Sarl Z.A. La piece 16, 1180 Rolle, Switzerland
DOP-LPB017
EN 54-12:2015 Line Detector using an Optical Beam, Fire Safety EN 54-17:2005 Short Circuit Isolator

Control Panel Compatibility

Please refer to the operation manual for the listed control panel for specific operation. Connect these projected beam smoke detectors to listed-compatible control panels only.

Product Listings

- CE
- ActivFire
- VdS
- BOSEC

The products shall be powered from a EN54-4 certified AC/DC Power converters to be in compliance for CE certification.

Table of Contents

1	Specifications	6
2	Dimensions	8
3	Before Installation	10
4	General Description	11
5	Special Applications	12
6	Approved Accessories	13
6.1	6500MMK	13
6.2	BEAMHKR	13
6.3	RTS151KEY (Test Function)	13
7	Package Contents	14
8	Detector Placement	15
8.1	Example for spacing according to NFPA 72	15
8.2	Example for spacing according to NFS 61.970 and the installation rule R7	16
9	Mounting Locations	18
10	Mounting Instructions	19
10.1	Mounting the Reflector	19
10.2	Mounting the Imager	20
11	Mounting Considerations for Single Ended Beam Detectors	21
12	Wiring Installation Guidelines	22
13	Installation/Alignment	25
13.1	Pre-alignment Checklist	25
13.2	Coarse Alignment	25
13.3	Fine Adjustment	26
13.4	Completing the Installation	27
13.5	Final Verification	27
14	Testing and Determining the Sensitivity of the Unit	29
14.1	Calibrated Test Filter	29
14.2	Remote Test Station	29
15	Operation After A Power Failure	31
16	Maintenance	32
17	Painting	33
18	Special Note Regarding Smoke Detector Guards	34
A	Appendix I. Operation Modes and Troubleshooting Guide OSI-RE*:	35
B	Appendix II. Reflector Drilling Template	37

1 Specifications

General	Value
Range:	16.4 to 328 Feet (5 to 100m)
Sensitivity:	Automatic sensitivity threshold level setting at start up. (25%, 30%, 40% and 50%)
Spacing:	30 to 60 Feet (9.1 to 18.3m) - Observe National and local regulations
Response Time:	ALARM - 20 seconds typical; TROUBLE - 30 seconds typical
Trouble Conditions:	Beam Blockage (partial or complete blockage due to any physical object blocking the line of sight of reflector) Improper Initial Alignment Self-compensation limit reached (service needed) In Alignment mode
Tolerance to building movement:	Horizontal: 0.8° Vertical: 1°
Test/Reset Features:	Electronic simulated smoke test from ground level Sensitivity Filter Remote Test and Reset Switch Capability
Indicators:	ALARM - Remote Output, Local LED (red) TROUBLE - Remote Output, Local LED (yellow), Blink Pattern Indicates Trouble Diagnostics NORMAL OPERATION - Local LED (flashing green once every 5 seconds) ALIGNMENT AIDS - Laser pointer and optical intuitive alignment guidance with directional arrows RELAYS - Alarm; Trouble

Environmental	Value
Temperature:	-4°F to 131°F (-20°C to +55°C). Product UL listed for use from 0°C to 37.8°C (32°F to 100°F). Note: For applications below 32°F (0°C), refer to section 5.
Humidity:	0% to 95% RH Non-condensing
IP Rating	IP55 * This beam detector is IP55 rated, therefore an IP55 compliant cable gland suitable to wire gauge must be used to maintain the IP55 rating.

Mechanical	Value
Shipping Weight:	Complete unit: 3.91 lbs (1.77kg)
Shipping Size:	10+7/8" X 8+7/8" X 7" (26.28 cm x 21.2 cm x 17.78 cm)
Mounting:	Wall only without optional accessories
Wiring:	22 AWG (0.64 mm, 0.34 mm ²) to 14 AWG (1.6 mm, 2.08 mm ²)
Adjustment Angle:	Detector 50° horizontal and 20° vertical beam alignment Reflector ±10° Horizontal and Vertical
Paintable Trim Ring:	May be painted using enamel or acrylic type paints

Electrical	Value
Voltage:	10.2 to 32 VDC (12 or 24VDC nominal)
Maximum Ripple Voltage:	6.0 volts (Peak-to-peak); Note: ripple must not fall below minimum operating voltage specification
Current @24 VDC:	Maximum Standby Current @32 VDC 7mA @24 VDC 11mA @12 VDC 20mA @10.2 VDC 50mA Maximum Alarm Current (LED on) @32 VDC 11mA @24 VDC 15mA @12 VDC 24mA @10.2 VDC 54mA
Relay Contacts:	0.5A at 30 VDC
Reset Time:	500 msec maximum
Start-up Time (after power up):	30 seconds maximum
Remote Outputs:	VOLTAGE – 10.2 to 32 VDC; Note: Output voltage same as device input voltage CURRENT - 15mA maximum; 6mA minimum; Note: Output current is limited by 2.2Kohm resistor
Remote annunciator RTS151KEY/RTS151KIT	VOLTAGE – 10.2 to 32 VDC CURRENT - min 9 mA - max 11 mA

2 Dimensions

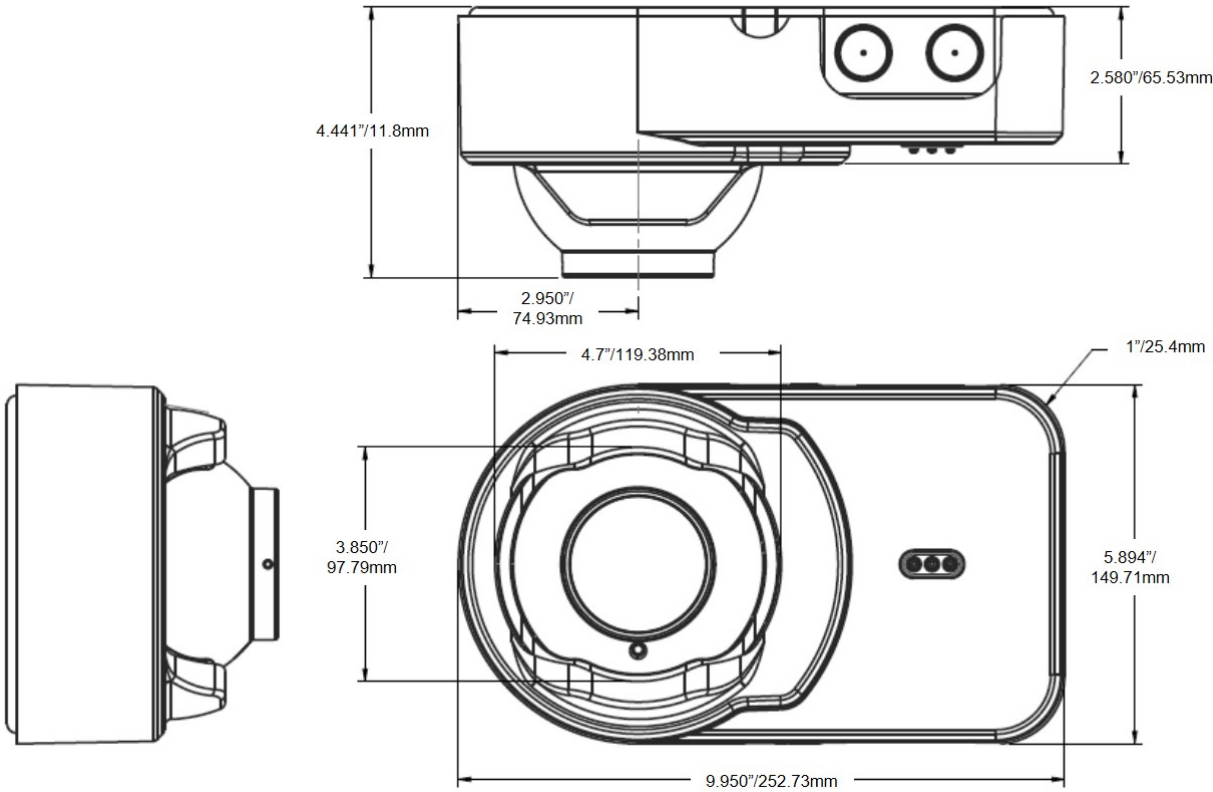

Figure 2-1: Detector dimensions

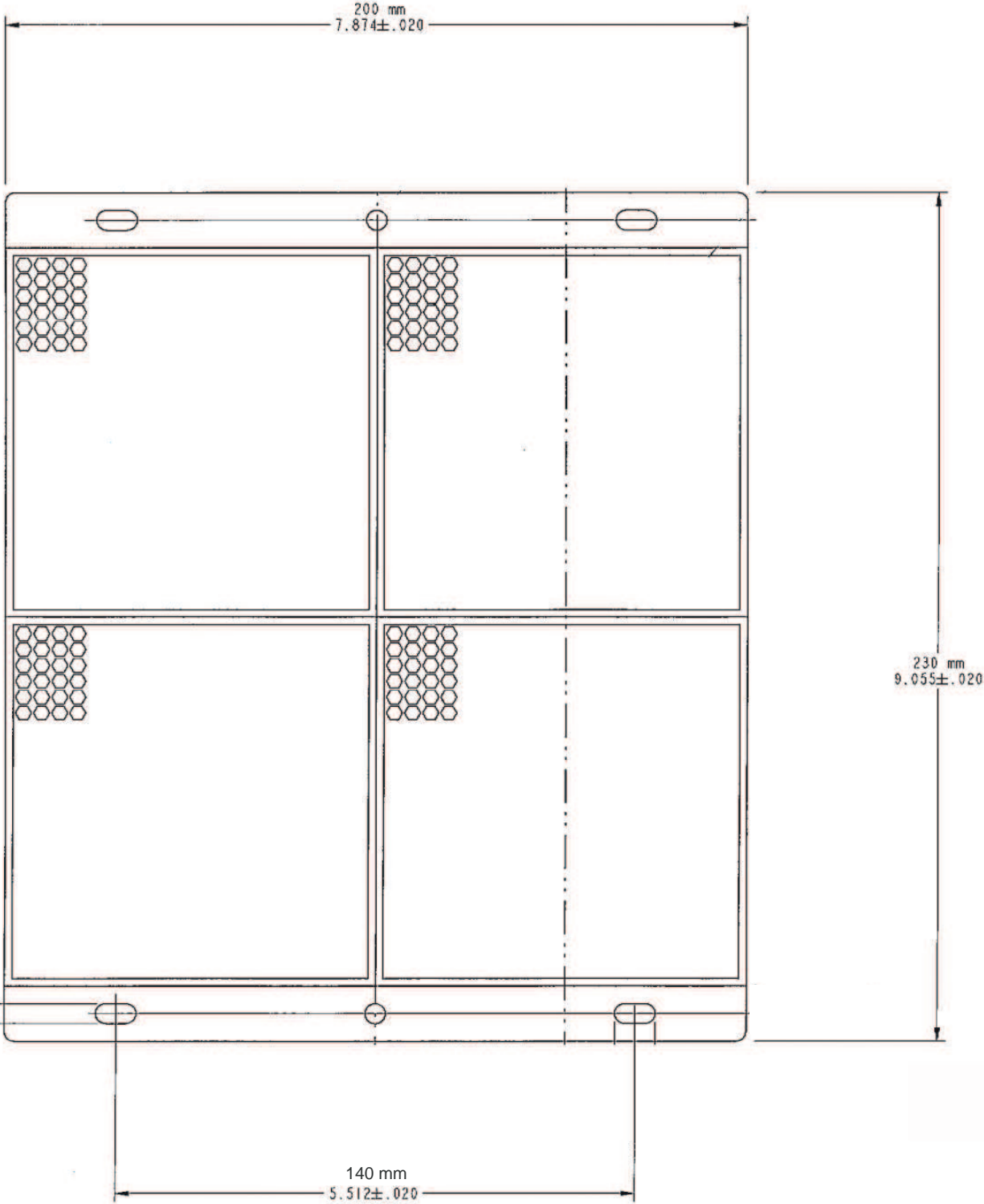

Figure 2-2: Reflector dimensions

3 Before Installation

Please thoroughly read this guide and applicable sections of OSID Global Application Note, document no. (25686). This manual is available online at www.xtralis.com.

4 General Description

The OSI-RE is a long range projected beam smoke imaging detector designed to provide open area protection. It is to be used with listed (UL, EN54, etc.). It is to be powered from a CE Certified AC/DC Power converters to be in compliance for CE certification. The detector consists of a transmitter/receiver unit and a reflector. Smoke entering the area between the transmitter/receiver and reflector causes a reduction in signal. When the obscuration reaches the alarm threshold (automatically set at the transmitter/receiver unit), the detector generates an alarm signal. Complete blockage of the beam causes a trouble signal. Slow changes in obscuration due to a build-up of dirt or dust on the lens of the detector are compensated for by a Microcontroller that continuously monitors the signal strength and periodically updates the alarm and trouble thresholds. When the self-compensation circuit reaches its limit, the detector generates a trouble signal, indicating the need for service.

Three LEDs on the detector indicate the current status: a red LED for alarm, a yellow LED for trouble, and a blinking green LED for standby operation. The alarm signal latches and can be reset by a momentary power interruption or by activating the remote reset input to the detector if using the remote test/reset station model RTS151KEY.

The yellow LED will blink in specific patterns to provide a diagnostic aid when diagnosing the cause of a trouble signal. Trouble signals automatically reset upon removing the cause of trouble. Red and yellow LEDs can be remotely connected to the remote Alarm and Trouble outputs. These outputs mimic the functions of the detector's red and yellow LEDs.

After commissioning the 4 arrows will indicate the level of automatically set sensitivity.

Each detector contains one change over relay contact for alarm signals and one change over relay contact for trouble signals. The trouble relay is fail safe and will open if power is removed from the detector. Thus, an additional EOL power supervision relay is not necessary.

The trouble contacts from all the beam detectors on one initiating circuit must be connected after the last indicating device on the loop. This prevents a single beam detector in trouble from disabling other initiating devices on the same loop.

5 Special Applications

Due to the inherent capabilities of projected type beam detectors they are often installed in locations where spot-type detection is impractical. Projected type beam smoke detectors are ideally suited for environmental conditions that might include high ceilings or areas with difficult access to the ceiling. Often these conditions present special problems for the installation of spot-type detectors and even greater problems for their proper maintenance. Due to the inherent flexibility of mounting locations and large coverage area of projected type beam detectors often the conditions above can be addressed or minimized. Some examples of applications for beam detectors might include aircraft hangars, cold storage warehouses, shipping warehouses, enclosed parking facilities, sporting arenas and stadiums or concert halls. Some of these environments might be considered not suitable for spot-type smoke detectors.

Before installing the transmitter/receiver unit or reflector in these types of applications special consideration should be given to ensure proper operation of the beam detector. The beam detector should not be installed in environments where heavy condensation or icing is likely. Condensation or icing of the reflector surface or the outer surface of the transmitter/receiver unit will obscure the light beam resulting in a nuisance alarm. If elevated humidity levels and rapidly changing temperatures can be expected then condensation will likely form and the application should not be considered acceptable for the beam detector.

In environments where a mild condensation is expected, the standard on-board lens heaters can be initiated by activating the heating switch located in the detector.

The beam detector should not be installed in locations where the transmitter/receiver unit, the reflector, or the optical pathway between them may be exposed to outdoor conditions such as rain, snow, sleet, or fog.

These conditions will impair the proper operation of the detector and must be avoided.

6 Approved Accessories

The following accessories can be purchased separately for use with this beam detector.

6.1 6500MMK



The 6500MMK allows reflected beam detectors and reflectors to be mounted to either a vertical wall or the ceiling. The kit allows for additional alignment range in cases where the detector and reflector cannot be mounted within 10° of each other. The kit includes the hardware necessary to mount either a single transmitter/receiver unit or a single reflector.

6.2 BEAMHKR



The BEAMHKR allows the reflector to operate in environments prone to the formation of condensation. Condensation forming on the reflector may result in trouble or false alarm conditions. BEAMHKR will lessen the likelihood of condensation by maintaining the reflector at a temperature that is slightly higher than surrounding air. The kit requires a 24V power supply.

6.3 RTS151KEY (Test Function)



The remote test accessory allows for the beam detector to be tested and reset remotely from ground level. The test accessory provides test and reset functions and green and red LEDs that mimic the LEDs on the detector.

7 Package Contents

- 1 Transmitter/Receiver Unit
- 1 Paintable Trim Ring
- 1 Reflector
- 4 Plug-in Terminal Blocks
- 1 OSI-RE Quick Start Guide

8 Detector Placement

This section of the manual discusses the placement of projected beam detectors.

Though this information is based upon industry expertise, it is intended to be used only as a technical guide. Always comply with the requirements of applicable codes and standards such as, NFPA 72, National Fire Alarm Code, BS 5839-1 NFS 61.970, R7, AS1670.1 and GB50166, etc. as well as directives of the Authority Having Jurisdiction (AHJ). For general information on the placement of detectors, read OSID Global Application Note, document no. (25686).

Projected beam detectors are usually located with their beams parallel to the ceiling. However, they can be mounted vertically or at any angle to protect the area involved. Since beam detectors sense the smoke build-up over a distance, they are ideal for locations with high ceilings. They can also be mounted on a wall or ceiling below the level of a spot type detector, reducing the effects of air stratification. Some typical locations would include large areas with high ceilings such as atriums, warehouses, and factories.

Note: Projected beam smoke detectors should always be mounted to stable mounting surfaces. For more information refer to sections 9.

Some fire codes specify spacing on a given centre-to-centre distance between detectors under ideal conditions. This spacing is based on rooms with smooth ceilings and no physical obstructions between the contents being protected and the detectors. Moreover, they are also based on a maximum ceiling height, and on the assumption that the value and the combustible nature of the contents of the room being protected do not warrant greater protection or closer spacing.

8.1 Example for spacing according to NFPA 72

As an example for NFPA 72, in a room with a smooth ceiling, detectors should be spaced horizontally between 30 and 60 feet (9.1 to 18.3m). One-half that spacing between the beam and the sidewall may be used as a guide. See Figure 8-1. The beam detector can be mounted with the transmitter/receiver on one wall and the reflector on the opposite wall, or both suspended from the ceiling, or any wall/ceiling combination. In the case of the ceiling mount, the distance from the end walls should not exceed one-quarter of the selected spacing (7.5 ft. [2.3m] maximum if the spacing is 30 ft. [9.1m]). See Figure 8-2.

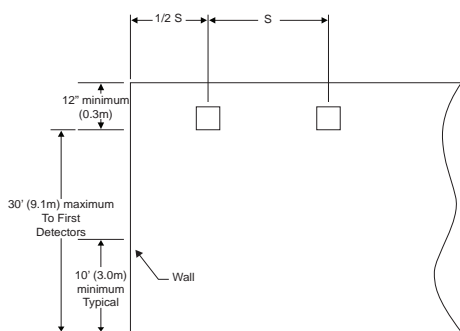

Figure 8-1: Smooth Ceiling (Side View)

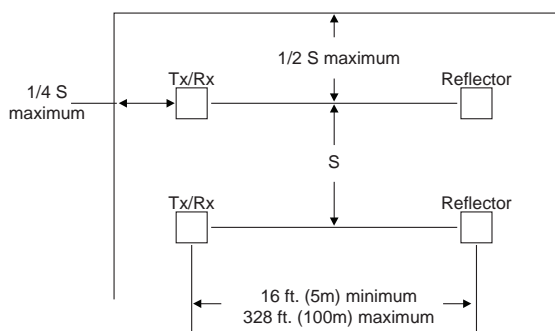

Figure 8-2: Smooth Ceiling (Top View)

In the case of peaked or sloped ceilings, codes may specify spacing of detectors by using horizontal spacing from the peak of the roof or ceiling. Figure 8-3 and Figure 8-4 show the spacing for both the shed type and peaked type sloped ceilings.

On smooth ceilings, beam smoke detectors should generally be mounted a minimum of 12 inches (0.3m) from the ceiling or beneath structural obstructions such as joists, ducts, etc. See Figure 8-1 In addition, beam smoke detectors should be mounted vertically at least 10 feet (3.0 m) from the floor to avoid common obstructions from normal building usage. In many cases, however, the location and sensitivity of the detectors shall be the result of an engineering evaluation that includes the following: ceiling heights above 30 feet (9.1 m) – refer to OSID Global Application Note, document no. (25686) for more information regarding the effects of stratification, structural features, size and shape of the room and bays, occupancy and uses of the area, ceiling height, ceiling shape, surface and obstructions, ventilation, ambient environment, burning characteristics of the combustible materials present, and the configuration of the contents in the area to be protected.

As a rule, reflective objects such as ductwork or windows should be a minimum of +/- 2° out of the center of the beam path of the beam.

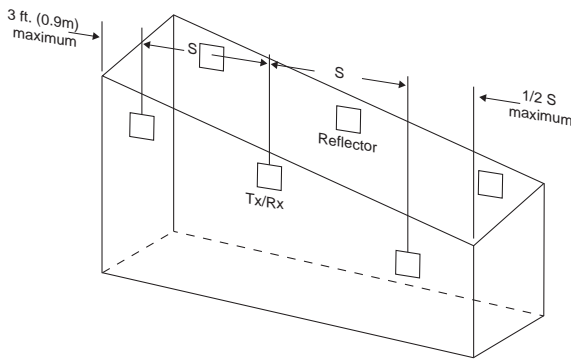

Figure 8-3: Sloped Ceiling (Shed Type)

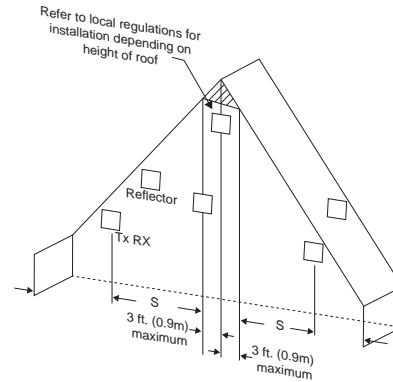

Figure 8-4: Sloped Ceiling (Peaked Type)

8.2 Example for spacing according to NFS 61.970 and the installation rule R7

The detectors must be positioned at a distance h_2 corresponding to the height under the ceiling

In the following table, you will find the requirements specified by NFS 61-970 and the installation rules R7 of the APSAD, the latter varying according to the height h_1 of the protected space. Distances h_2 are given for flat ceilings. These values will vary depending on the geometry of the room and the specific installation conditions.

Hauteur du local h_1 en m	Height of installation under ceiling h_2 in m
$h_1 \leq 5$	$0.3 < h_2 \leq 0.5$
$5 < h_1 \leq 12$	$0.5 < h_2 \leq 2$
$12 < h_1 \leq 15^*$	$0.5 < h_2 \leq 3$ for the higher level

* When the room height is greater than 12 m, the risk analysis may lead to installing a second level of detection.

The maximum monitoring width l also depends on the height of the room, and is defined in the table below.

Height of room in m	Maximum width of surveillance l_1 or l_2 in m (see drawing below)
$h_1 \leq 5$	4
$5 < h_1 \leq 12$	5
$12 < h_1 \leq 15^*$	5

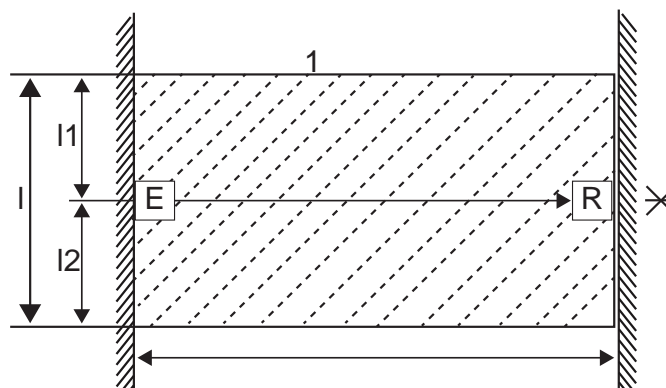

Figure 8-5: Supervised Area

Each detector positioned according to the drawing above is able to monitor a floor area (A) varying with the height of the room (h_1). This surface is in the form of a polygon rectangle of width ($l = l_1 + l_2$) and length (L). This method is applicable for risks with flat or sloped roofs. In the latter case, the height of the room is measured at the highest point.

For more information about installation requirements, refer to the standard NFS 61- 970 or the APSAD R7 Installation Rule.

9 Mounting Locations

Beam detectors require a stable mounting surface for proper operation. A surface that moves, shifts, vibrates, or warps over time will make the system prone to nuisance alarm or trouble conditions. Initial selection of a proper mounting surface will eliminate false alarms and nuisance trouble signals.

Mount the detector on a stable mounting surface, such as brick, concrete, a sturdy load-bearing wall, support column, structural beam, or other surface that is not expected to experience vibration or large movement over time. **DO NOT MOUNT** the beam detector on corrugated metal walls, sheet metal walls, external building sheathing, external siding, suspended ceilings, steel web trusses, rafters, non-structural beam, joists, or other such surfaces.

In cases where only one stable mounting surface as defined above can be used, the transmitter/receiver unit should be mounted to the stable surface and the reflector should be mounted to the less stable surface. The reflector has a much greater tolerance for the unstable mounting locations defined above.

10 Mounting Instructions

10.1 Mounting the Reflector

Mount the reflector first.

The reflector can be mounted to the wall using the supplied drilling template see (*B Appendix II. Reflector Drilling Template*). The reflector has 4 mounting holes, one in each corner.

All four-hole locations should be used to provide a secure mounting. The reflector must be mounted such that it is within 10° in both the X and Y planes of the transmitter/receiver unit. See Figure 10-1 and Figure 10-2. The reflector must also be mounted such that the plane of the reflector is perpendicular to the optical line of sight to the transmitter/receiver unit. The maximum tolerance for non-perpendicular mounting locations is 10° . See Figure 10-3.

If the reflector cannot be mounted within 10° of the transmitter/receiver unit then the multi-mount kit (6500MMK) may be used to provide greater angular adjustment of the transmitter/receiver unit. If the perpendicular plane of the reflector cannot be mounted within 10° of the optical line of sight then the multi-mount kit can be used for the reflector.

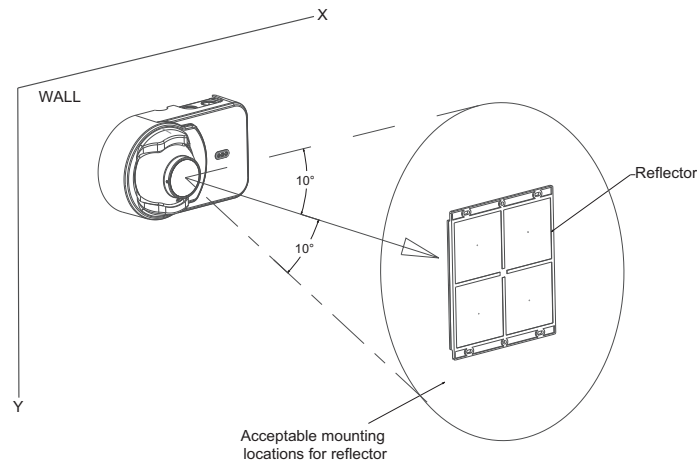

Figure 10-1: Reflector Mounting Guidelines

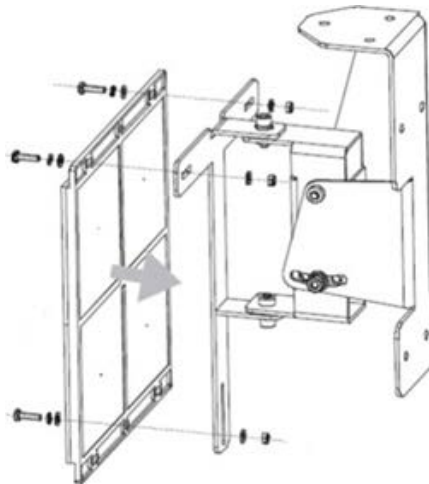

Figure 10-2: Reflector Mounting Guidelines

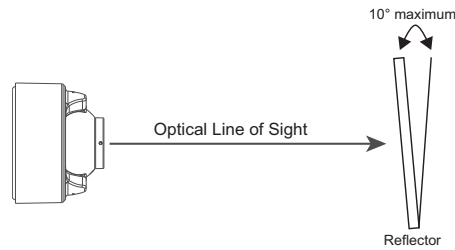

Figure 10-3: Reflector Mounting Guidelines

10.2 Mounting the Imager

The transmitter/receiver unit can be surface mounted, Cable knock-outs are provided top, bottom and back in the back box.

The transmitter/receiver unit may be mounted over a recessed junction box.

The cavity behind the detector is then used for routing of the wiring from the junction box to the terminal blocks on the detector by drilling holes through the detector's back box.

The transmitter/receiver unit should be mounted to the wall such that the unit covers the recessed junction box in the wall completely.

The transmitter/receiver unit can be mounted to the wall using the back box pilot holes for the 4" junction box. The detector base has 6 pilot mounting keyholes spread around the base, see Figure 10-4. Any suitable number of locations should be used to provide a secure mounting.

If the large knock out is not used, than use as a minimum this one and the most left mounting hole to mount the detector. If the large knock-out is removed use the left mounting hole and one top and one bottom mounting hole near to the knock-out.

The outer housing of the beam detector is held to the base using three screws. To mount the detector, you must remove the outer housing first.

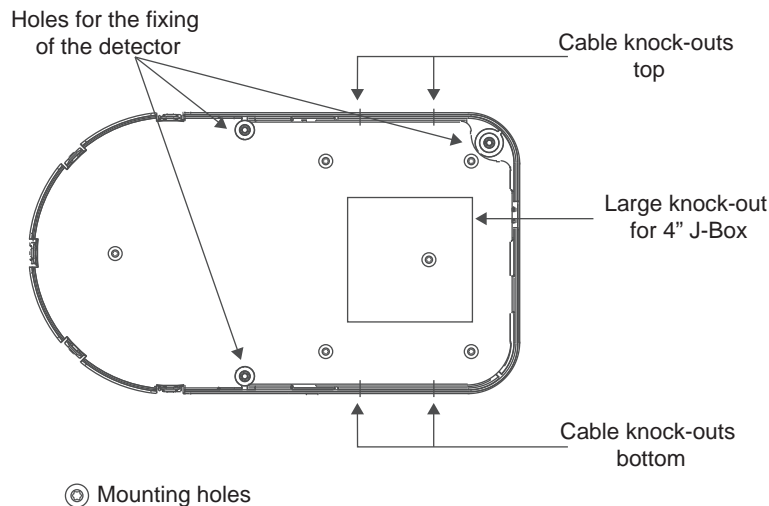

Figure 10-4: Mounting pilot holes

11 Mounting Considerations for Single Ended Beam Detectors

There must be a permanent clear line of vision between the detector and the reflector. Reflective objects must not be near the line of vision between the detector and reflector. Reflective objects too near to the line of sight can reflect the light beam from the transmitter to the receiver. If this occurs, the detector will not be able to distinguish these reflections from those of the reflector and the protected space will be compromised.

Reflective objects such as ductwork or windows should be a minimum of 15 inches (38.1cm) from the path of the beam (TBC). In cases where reflective objects cannot be avoided, the complete reflector blockage test can be used to determine if the installation is acceptable.

For more information refer to section 14 and 16.

Light sources of extreme intensity such as sunlight and halogen lamps, if directed at the receiver, can cause a dramatic signal change resulting in fault signals. To prevent this problem direct sunlight into the transmitter/receiver unit should be avoided. There should be a minimum of 10° between the pathway of the light source and detector and the line of sight between detector and reflector.

Operation of the detector through panes of glass should be avoided. Since single ended beam detectors operate on a reflection principle, a pane of glass perpendicular to the line of sight between the detector and the reflector can reflect the light beam from the transmitter to the receiver. If the application requires operation through glass, use the dual ended imaging smoke beam detector from the OSID family offering.

Where high ceilings (more than 30 feet or 9.1 meters) are present additional beam smoke detectors mounted at multiple heights may be required to detect smoke at lower levels. For more information refer to section 8.

12 Wiring Installation Guidelines

Always install all wiring in compliance with the National Electrical Codes, and/or the applicable local codes, and any special requirements of the local authority having jurisdiction. Proper wire gauges and suitable means for strain relief should be used. The conductors used to connect beam smoke detectors to control panels and accessory devices should be color-coded to reduce the likelihood of wiring errors. Improper connections can prevent a system from responding properly in the event of a fire.

Installation wire used for the beam detector shall be no smaller than 22 AWG (1.0 mm²). For best system performance, all wiring should be twisted pair and installed in separate grounded conduit. Do NOT mix fire system wiring in the same conduit as any other electrical wiring.

When installing the beam smoke detector in applications where the head unit will be mounted to either a wall or the ceiling using the multi-mount kits (6500MMK) and flexible conduit will be used. The multi-mount kit 6500MMK must be installed with the cable before wiring the unit.

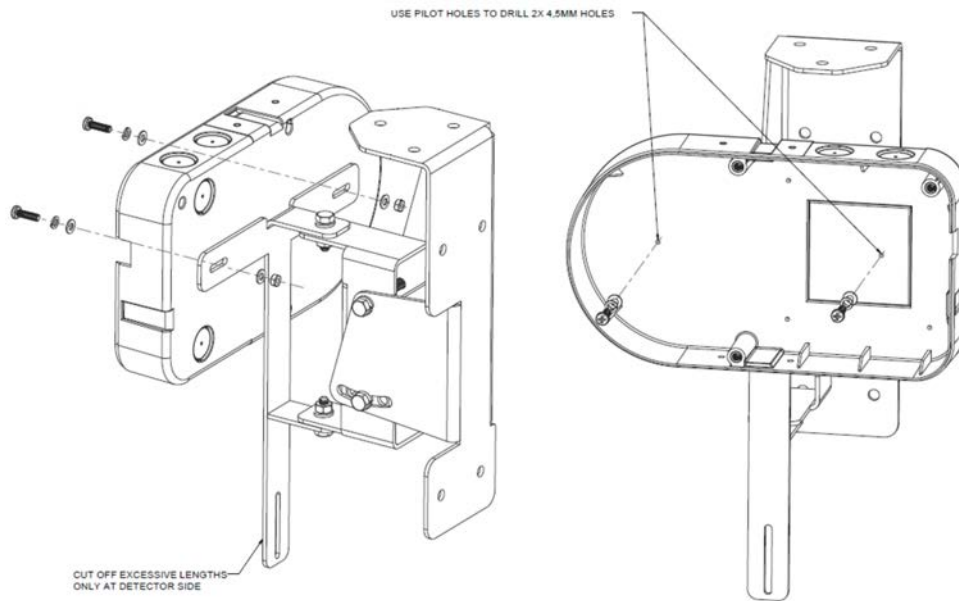

Figure 12-1: Detector Mounting Guidelines

When the detector has been mounted over a recessed junction box, all wiring should be routed out of the box and behind the detector to the bottom of the detector where the terminal blocks are located. When installing the wiring in the junction box be sure to leave enough wire in the box to connect to the terminal blocks. (Approximately 9" [23cm] of wire outside of the junction box will be required for proper installation). All wiring to the detector is done via pluggable terminal blocks. To properly make electrical connections strip approximately 1/4" (6mm) of insulation from the end of the wire, sliding the bare end of the wire under the clamping plate screw.

Figure 12-2 shows the proper wiring diagram for either class A or class B operation.

Figure 12-3 shows all the wiring connections to the transmitter/receiver unit.

Figure 12-4 shows the connections that are necessary when using one of the optional remote test stations.

Figure 12-5 shows the remote outputs for trouble and alarm.

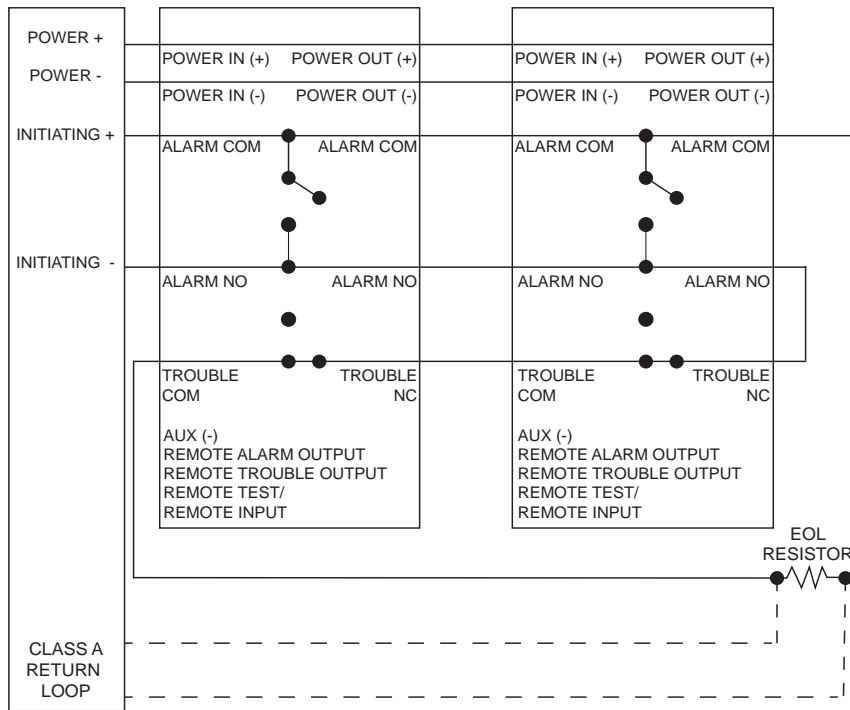

NOTE: If other sensors are installed on the same loop, a listed end of line power supervision module is required.

Figure 12-2: Wiring Diagram

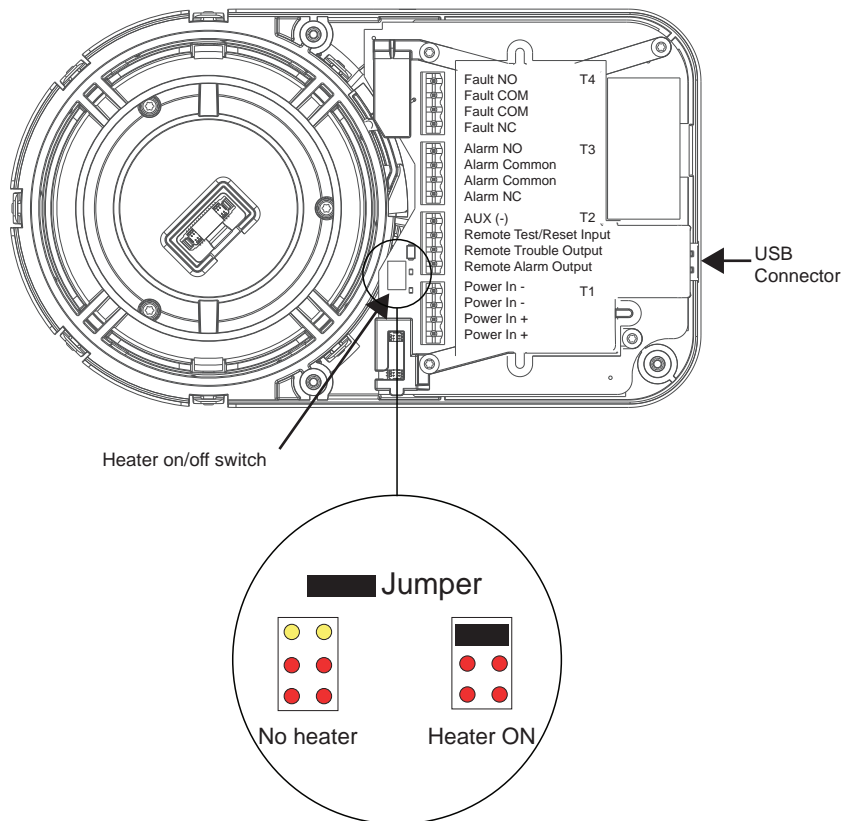
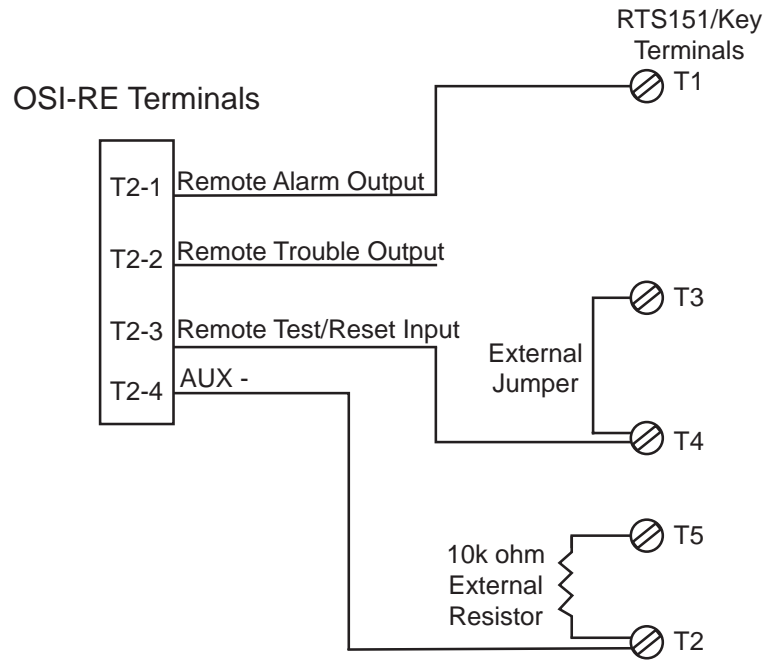

Figure 12-3: Wiring Connections at Detector

Warning: Disable the zone or system before applying power to the beam detector to prevent unwanted alarms. When applying power to the beam detector before the alignment procedure has been completed the detector will signal a trouble condition.



Wiring: Single 2 pair cable , 0.8mm², unshielded.

Figure 12-4: Wiring Diagram (RTS451 or RTS151)

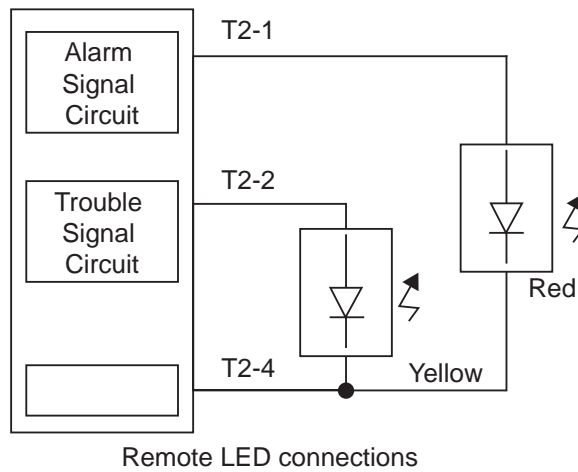

Figure 12-5: Wiring Diagram (Remote LEDs)

13 Installation/Alignment

Please make sure to complete all steps to ensure a successful installation.

Proper application, mounting, alignment, and set-up will minimize false alarms and nuisance trouble signals.

13.1 Pre-alignment Checklist

- Ensure that both the detector and reflector are mounted securely to stable surfaces.
- Ensure that all wiring is correct.
- Ensure that terminal blocks are fully seated into their receptacles on the detector.
- Complete any wiring dressing to minimize movement to the detector once the alignment procedure is completed.
- Ensure that the line of sight between the detector and reflector is clear and that reflective objects are not too near. See mounting instructions for more details.
- Remove the protective film from the lens surface of the imager.
- Ensure that both the detector and reflector are mounted within their operational parameters for off axis angles. See Mounting Instructions for more details.
- Disable the zone or system to prevent unwanted alarms before applying power.
- Ensure power to the detector is "ON".

You are now ready to begin the alignment procedure.

13.2 Coarse Alignment

Ensure that neither you nor any other objects are in the line of sight between the detector and the reflector.

Make sure the eyeball locking mechanism is unlocked. The lever is now in the 3 o'clock position and the eyeball moves freely.

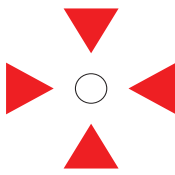

By powering up the unit, the detector goes in alignment mode.

If the reflector is not in the field of view of the imager all 4 arrows will blink red.

For longer distances or in heavy lit environments use the OSP-002 Laser Alignment tool to roughly align the OSI-RE eyeball with the reflector. Make sure there are no people or objects obstructing your view of the reflector. This is also a good time to confirm that there are no obstructions or reflective objects within 15" (38.1cm) of the beam's path.

Insert the OSP-002 in the slot provided in the eyeball at 06.00 and move the eyeball.

The eyeball moves freely 50° horizontally and 20° vertically.

Gently move the eyeball till the red laser spot is on or near the reflector.

Once on the reflector, the laser dot will be clearly visible.

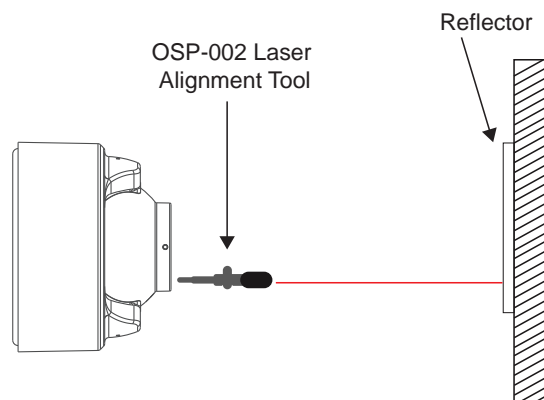

Figure 13-1: Coarse Alignment

13.3 Fine Adjustment

It is important to be well aligned as the IR power drops rapidly out of the centre of the beam.

The maximum beam size is dependent on the distance (D) between detector and reflector and can be calculated as $0.07 \times D$.

Example, at 70 m/230 ft., the diameter of the beam will be +/- 5m/16.4 ft.

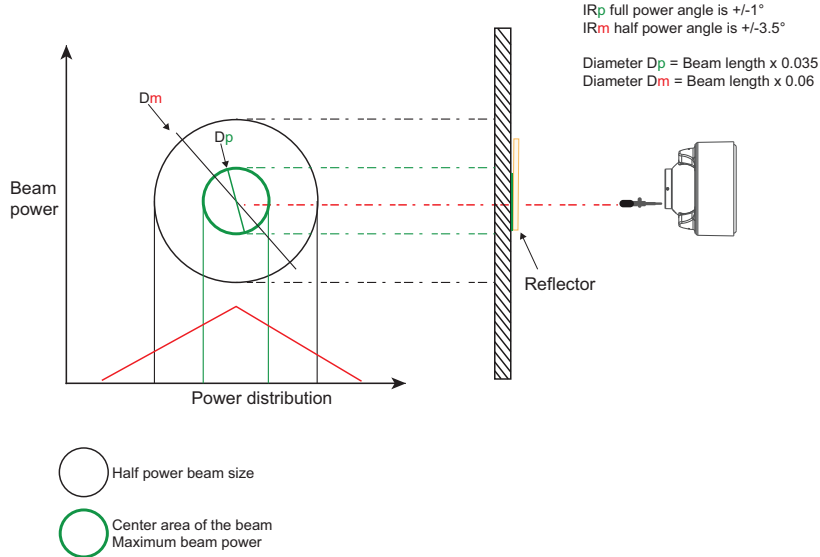

Figure 13-2: Beam Power Distribution

The 4 arrows will intuitively guide the user to optimal eyeball alignment. All arrows and the middle green LED must blink green for the eyeball to be optimal aligned. Likely the alignment process will start with all arrows red.

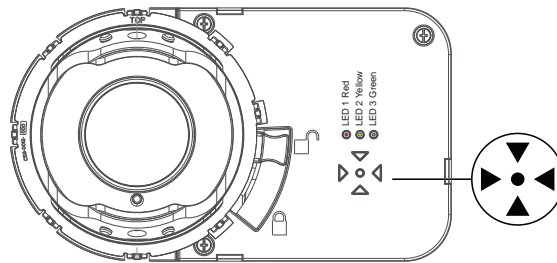

Figure 13-3: Arrow Array

Gently move the eyeball and let the arrow's colour, changing colour red to orange to green, as the alignment improves guide you till the all arrows and the middle LED turn green.

Example:

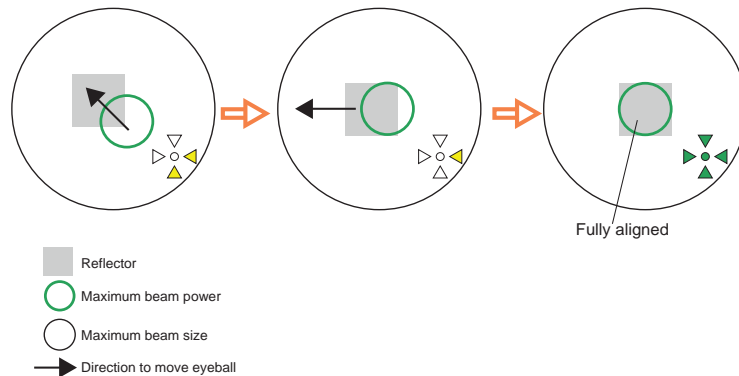

Figure 13-4: Arrow Array Color Alignment Guidance

The unit is now optimal aligned. Now gently lock the eyeball by moving the lever down till the eyeball is solidly locked. The lever is now in the 5 o'clock position and you feel the resistance of the locked position.

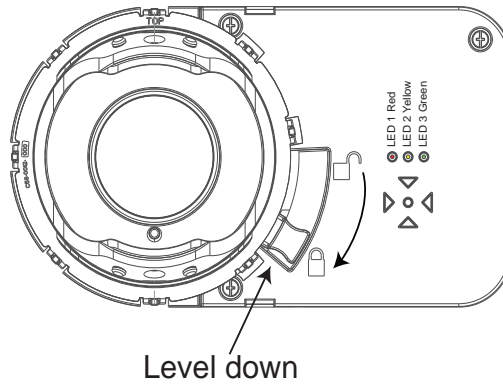

Figure 13-5: Locking and Securing the Eyeball

Table 13-1: Sensitivity versus distance

Distance detector-reflector ft.	Distance detector-reflector m	Selected sensitivity	Attenuation dB
15 ft to 30 ft.	5 m to 9 m	25% obs.	1.249
30 ft to 70 ft.	9 m to 21 m	30% obs.	1.549
70 ft to 150 ft.	21 m to 46 m	40% obs.	2.218
150 ft to 330 ft	46 m to 100 m	50% obs.	3.010

By locking the eyeball an internal switch is activated and the detector will now start its initiation or commissioning process. A normal commissioning process takes roughly 10 seconds. During the commissioning process, the beam path has to remain clear from object intrusions.

In this process cycle the detector will measure the size of the reflector in its FOV and determine the distance between detector and reflector. Based on this measurement, the sensitivity will be automatically set to the optimum sensitivity for the specific distance.

The process is finalised when the 4 arrows and the middle green LED stop blinking green. Before going in operational mode, the detector will show its set sensitivity. This is shown by blinking the 4 arrows. The number of blinks is, reflecting the % of selected obscuration/sensitivity. The key is; 1 blink = 25%, 2 blinks = 30%, 3 blinks = 40% and 4 blinks= 50%. After 5 seconds, the scenario will be repeated a second time and than, the arrows LEDs go out and the front OK LED blinks green. The detector is now in operation and working correctly.

13.4 Completing the Installation

The paintable cover can now be snapped over the front to secure the locking lever and to hide the alignment LEDs and locking mechanism.

If the cover was painted, ensure that the paint is completely dry before installing. Mark the set sensitivity on the inside the cover for later use.

13.5 Final Verification

1. Block the entire reflector with an opaque material. Nearly any non-reflective opaque material will do, including the installation sheet or the cardboard packaging inserts.

The detector should enter a trouble condition, indicated by the fault relay and the yellow LED (see *A Appendix I. Operation Modes and Troubleshooting Guide OSI-RE**:) after 30 seconds. If the detector does not enter a trouble condition, there is a problem with the installation. Refer to troubleshooting section in *A Appendix I. Operation Modes and Troubleshooting Guide OSI-RE**: . for assistance.

2. Complete by testing the detector using the test filter to create an alarm.

Note: Before testing, notify the proper authorities that the smoke detector system is undergoing maintenance, and therefore the system will be temporarily out of service. Disable the zone or system undergoing maintenance to prevent unwanted alarms.

Before testing the detector, check for the presence of the flashing green OK LED at the receiver, making sure not to disturb or block the beam. If it does not flash and the detector is not in trouble or alarm, power has been lost to the detector (check the wiring).

14 Testing and Determining the Sensitivity of the Unit

14.1 Calibrated Test Filter

14.1.1 Testing at the Imager

A quick test can be performed at the imager side by using the red acrylic test filter, OSP-004.

- Place the filter in front of the imager's lens. The detector should enter alarm within 1 minute.
- The detector can be reset with the remote reset or by momentarily interrupting power.
- Notify the proper authorities that the system is back on line.

At each reset action, the detector will show its set sensitivity.

After the RED alarm LED is off, the yellow alignment arrows on the front will indicate the set sensitivity by the number of blinks from the arrows to indicate the set level.

The key is; 1 blink = 25%, 2 blinks = 30%, 3 blinks = 40% and 4 blinks = 50%.

After 5 seconds, the scenario will be repeated a second time.

After this, the detector will now be in normal working condition.

14.1.2 Testing at the Reflector

A thorough test should be performed at the reflector side, see "Testing at the Imager". The sensitivity of the detector must be noted during the quick test at the end of the initial set-up procedure.

1. The sensitivity of the detector can be verified using the test filter to cover the reflector. The detector can be reset with the remote reset or by momentarily interrupting power.
2. Notify the proper authorities that the system is back on line.

If the detector fails this test several steps should be taken to determine if the detector is faulty or simply needs to be re-adjusted before returning the unit.

These steps include:

1. Verify all wiring connections and appropriate power is applied to the detector.
2. Verify that the optical line of sight is free from obstructions and reflective objects.
3. Apply the maintenance procedure in this manual. Repeat the test procedure.
4. If the detector still fails the test procedure proceed with step 4.
5. Repeat the alignment procedure in this manual. If the alignment procedure is successful repeat the test procedure. If the detector still fails the test it should be returned.

14.2 Remote Test Station

The detector can be tested remotely using the remote test station.

Follow instructions included with the test station for proper use. See Figure 12-4 (Remote Test Station) for wiring diagram.

When activating the test, the detector will reduce the power output of the IR signal to the point where it drops below the automatically set sensitivity at the detector.

The detector will remain in alarm condition for as long as the test switch is activated. The detector can be reset by selecting the reset position on the RTS151KEY.

The remote fault LED will blink the set sensitivity of the detector. The number of blinks, similar to number of blinks from the arrows, will represent the set sensitivity and the sequence is repeated every 3 seconds till the detector is reset.

The LEDs at the remote test station will mimic the detector front LEDs.

Note: For the OSI-RE this test does not satisfy the requirements of NFPA72 for periodic maintenance and sensitivity verification of beam type detectors.

For the OSI-RE this test in conjunction with the complete reflector blockage test (see step 4 of the Installation/Alignment procedure in this manual) does satisfy the requirements of NFPA72 for periodic maintenance and sensitivity verification of beam type detectors.

If the detector fails this test several steps should be taken to determine if the detector is faulty or simply needs to be re-adjusted before returning the unit for repair. These steps include:

1. Verify all wiring connections and appropriate power is applied to the detector.
2. Verify that the optical line of sight is free from obstructions and reflective objects.
3. Apply the maintenance procedure in this manual. Repeat the test procedure. If the detector still fails the test procedure proceed with step 4.
4. Repeat the alignment procedure in this manual. If the alignment procedure is successful repeat the test procedure. If the detector still fails the test it should be returned.

Detectors must be tested after installation and following periodic maintenance.

Congratulations. You have completed the final installation and alignment procedure.

15 Operation After A Power Failure

The detector has the reflector location/position, set sensitivity and other commissioning parameters permanently memorised after the initialisation process.

After a power failure of any duration, when the supply is restored the detector will check the possible new situation versus its memorised data.

If the reflector is found in the same position and all parameters are within acceptable limits, the detector will resume its operation and go out of fault condition.

If any significant parameters have changed, it will remain in a fault condition and a re-initialisation will be required.

16 Maintenance

Note: Before cleaning the detector, notify the proper authorities that the smoke detector system is undergoing maintenance, and therefore the system will be temporarily out of service. Disable the zone or system undergoing maintenance to prevent unwanted alarms.

1. Carefully clean the outer housing lens face. A damp soft cloth with a mild soap may be used. Avoid products with solvents or ammonia.
2. Carefully clean the reflector. A damp soft cloth with a mild soap may be used. Avoid products with solvents or ammonia.
3. Notify the proper authorities that the system is back on line.

17 Painting

The outer aesthetic ring may be painted using a spray or brush type paint of appropriate type. For more information refer to section 1.

Note: Never paint the flat lens surface of the imager.

18 Special Note Regarding Smoke Detector Guards

Smoke detectors are not to be used with detector guards unless the combination has been evaluated and found suitable for that purpose.

A Appendix I. Operation Modes and Troubleshooting Guide OSI-RE*:

Modes	Red and Remote Alarm Output (LED 1)	Yellow and Remote Trouble Output (LED 2)	Green (LED 3)	Initiating means	Comments and Troubleshooting Tips
Power On	Off	Blink	Off	Apply Power from discharged state.	<ul style="list-style-type: none"> All wiring correctly done. Address switches set.
Alignment	Off	Blink	Off	Lever in 3:00 position and commissioning is active.	<ul style="list-style-type: none"> Ready to perform alignment. Follow guidance from the 4 arrows to correctly align.
Initializing/Commissioning	Off	Blink	Off	Lock lever in 6:00 position to start commissioning.	<ul style="list-style-type: none"> Commissioning and setting sensitivity. Do not interrupt beam.
Normal	Off	Off	Blink	Successful completion of initialization or detector reset.	<ul style="list-style-type: none"> Initializing finished. Detector operates normal in quiescent condition. Detector successfully reset.
Alarm	On	Off	Off	Smoke, Test Filter or RTS151KEY Test Station.	<ul style="list-style-type: none"> Blinks till reset from FACP or RTS151KEY.
Trouble-Drift Compensation	Off	3 Quick Blinks	Blink	Long Term Drift Reference Out of 20% Range.	<ul style="list-style-type: none"> Reduced IR Signal. Clean detector and reflector.
Trouble-Beam Blockage	Off	4 Quick Blinks	Blink	Beam blockage or detector out of alignment.	<ul style="list-style-type: none"> Remove blockage or re-align detector. Faulty unit.
Trouble-Imager saturation	Off	5 Quick Blinks	Blink	Imager saturated.	<ul style="list-style-type: none"> Sunlight or very strong light into detector or reflector. Re-position detector or reflector. Remove light source.
Test activated-Pass Result	On	Blinks the set sensitivity by number of blinks (1-4). Repeats every 3 seconds till reset.	Off	FACP or RTS151KEY.	<ul style="list-style-type: none"> Remains in alarm until reset by FACP or RTS151KEY. Arrows blink sensitivity level that was selected automatically.

* Refer to Figure 13-3 and Figure 13-5 for LEDs 1, 2, and 3.

Blink patterns

1. OK/Green:
 - Imager will flash green once every 5 seconds.
2. Alarm/Red:
 - Imager red solid on.
3. Faults/Yellow:
 - Number of pulses identifies type of fault.
 - Rhythm; every pulse 15ms ON/15ms OFF, repeat after 2 seconds till fault has disappeared.
 - Blinks only highest priority fault.

B Appendix II. Reflector Drilling Template

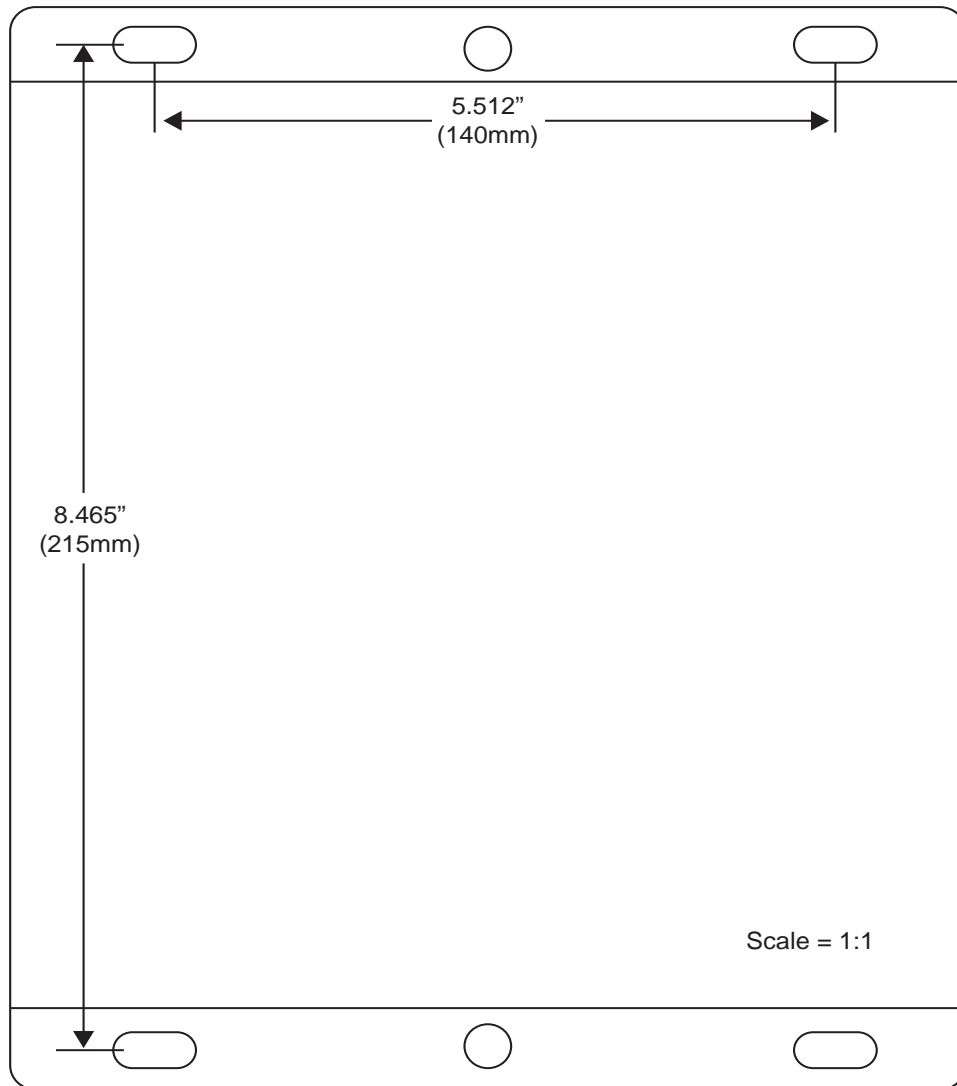

FCC STATEMENT

This device complies with part 15 of the FCC Rules. Operation is subject to the following two conditions: (1) This device may not cause harmful interference, and (2) this device must accept any interference received, including interference that may cause undesired operation.

Note: This equipment has been tested and found to comply with the limits for a Class B digital device, pursuant to Part 15 of the FCC Rules. These limits are designed to provide reasonable protection against harmful interference in a residential installation. This equipment generates, uses and can radiate radio frequency energy and, if not installed and used in accordance with the instructions, may cause harmful interference to radio communications. However, there is no guarantee that interference will not occur in a particular installation.

If this equipment does cause harmful interference to radio or television reception, which can be determined by turning the equipment off and on, the user is encouraged to try to correct the interference by one or more of the following measures:

- Reorient or relocate the receiving antenna.
- Increase the separation between the equipment and receiver.
- Connect the equipment into an outlet on a circuit different from that to which the receiver is connected.
- Consult the dealer or an experienced radio/TV technician for help.

THREE-YEAR LIMITED WARRANTY

Xtralis warrants its enclosed smoke detector to be free from defects in materials and workmanship under normal use and service for a period of three years from date of manufacture. Xtralis makes no other express warranty for this smoke detector.

No agent, representative, dealer, or employee of the Company has the authority to increase or alter the obligations or limitations of this Warranty. The Company's obligation of this Warranty shall be limited to the repair or replacement of any part of the smoke detector which is found to be defective in materials or workmanship under normal use and service during the three-year period commencing with the date of manufacture.

Use Xtralis' RMA (Return Authorization Number) procedure to return goods under warranty.

Please include a note describing the malfunction and suspected cause of failure. The Company shall not be obligated to repair or replace units which are found to be defective because of damage, unreasonable use, modifications, or alterations occurring after the date of manufacture. In no case shall the Company be liable for any consequential or incidental damages for breach of this or any other Warranty, expressed or implied whatsoever, even if the loss or damage is caused by the Company's negligence or fault. Some states do not allow the exclusion or limitation of incidental or consequential damages, so the above limitation or exclusion may not apply to you. This Warranty gives you specific legal rights, and you may also have other rights which vary from state to state.

