

OSID-DE

SMOKE DETECTION



Open-area Smoke Imaging Detection (OSID-DE) by Xtralis is a new innovation in projected beam smoke detection technology. By using advanced dual wavelength projected beams and optical imaging technology for early warning smoke detection, OSID-DE provides a low-cost, reliable and easy-to-install solution that overcomes typical beam detection issues such as false alarm incidents and alignment difficulties.

Unique Detection Technology

The OSID-DE system measures the level of smoke entering beams of light projected over an area of protection. A single OSID-DE Imager can detect up to seven Emitters to provide a wide coverage area. Two innovations in smoke detection technology have been developed for the revolutionary OSID-DE smoke detector:

Dual Wavelength Particle Detection

The beam projected from each Emitter contains a unique sequence of ultraviolet (UV) and infrared (IR) pulses that are synchronised with the Imager and enable the rejection of any unwanted light sources.

By using two wavelengths of light to detect particles, the system is able to distinguish between particle sizes. The shorter UV wavelength interacts strongly with both small and large particles while the longer IR wavelength is affected only by larger particles. Dual wavelength path loss measurements therefore enable the detector to provide repeatable smoke obscuration measurements, while rejecting the presence of transient dust particles or solid intruding objects.

Optical Imaging with a CMOS Imaging Chip

An optical imaging array in the OSID-DE Imager provides the detector with a wide viewing angle to locate and track multiple Emitters. Consequently, the system can tolerate a much less precise installation and can compensate for the drift caused by natural shifts in building structures.

Optical filtering, high-speed image acquisition and intelligent software algorithms also enable the OSID-DE system to provide new levels of stability and sensitivity with greater immunity to high level lighting variability.

Operation

Status information (Fire Alarm, Trouble and Power) is communicated through the Imager via Status LEDs, dedicated Trouble and Alarm relays, and the Remote Indicator interface. Specific Trouble (Fault) conditions are identified through coded flashes of the Trouble LED. An internal heating option is also provided on the Imager to prevent condensation on the optical surface, and a reset input enables an external signal to reset the device.

Simple Installation and Maintenance

The OSID-DE system consists of up to seven Emitters for the 90° Imager unit, located along the perimeter of the protected area, and an Imager mounted opposite. Each component can be mounted directly to the surface or can be secured with the supplied mounting brackets. Battery powered Emitters with three or five years battery life are also available to reduce installation time and cost. On the Imager, a termination card provides all field wiring terminals, and DIP switches enable the user to configure the detector for particular applications.

Alignment of the Emitter is simply achieved using a laser alignment tool to rotate the optical spheres until the laser beam projected from the alignment tool is close to the Imager.

The Imager is aligned in a similar way so that its Field of View (FOV) encompasses all Emitters. A Trouble or Fault will be indicated if an Emitter is missing or outside the Imager field of view.

The OSID-DE system is highly tolerant to transient dust and dirt and requires little maintenance in practice. Preventative maintenance is limited to occasionally cleaning the optical faces of the detector components.



Features

- Maximum detection range of 295 ft (90m) for the OSI-10
- Dual wavelength LED-based smoke detection
- Optical imaging with CMOS imaging chip
- On-board event log for fault and alarm diagnostics
- High tolerance to false alarm due to building movement
- High tolerance to transient dust, steam and intrusion of solid objects
- Easy alignment with large adjustment and viewing angles
- No need for precise alignment
- Tolerant of alignment drift
- Automatic commissioning in under ten minutes

- Simple DIP switch configuration
- Simple and easy maintenance requirements
- Three selectable alarm thresholds
- Status LEDs for Fire, Trouble and Power
- Conventional alarm interface for straightforward fire system integration

Listings / Approvals

- UL
- ULC
- FM
- CSFM
- FCC

Configuration Options for UL Installations

OSID-DE systems may be configured to suit a range of detection spaces by selecting the number of Emitters and type of Imager. Each type of Imager differs by the lens used in the unit, which determines the field of view and range of the system.

Imager Lens Type	UL Sensitivity	Detection Range					
		Standard Power		High Power			
		Battery / Wired		Battery		Wired	
		Min	Max	Min	Max	Min	Max
10°	Med	98 ft (30 m)	164 ft (50 m)	-	-	-	-
	Low	98 ft (30 m)	295 ft (90 m)	-	-	-	-
90°	High	26 ft (8 m)	82 ft (25 m)	65 ft (20 m)	82 ft (25 m)	65 ft (20 m)	82 ft (25 m)
	Med	55 ft (17 m)	111 ft (34 m)	65 ft (20 m)	164 ft (50 m)	65 ft (20 m)	164 ft (50 m)
	Low	82 ft (25 m)	111 ft (34 m)	82 ft (25 m)	164 ft (50 m)	82 ft (25 m)	223 ft (68 m)

* Maximum Distances measured for the Center Field of View of the Imager. For more details on distances for the Imager, see the OSID-DE Product Guide (Doc. No. 15204).

Emitter / Imager Dimensions

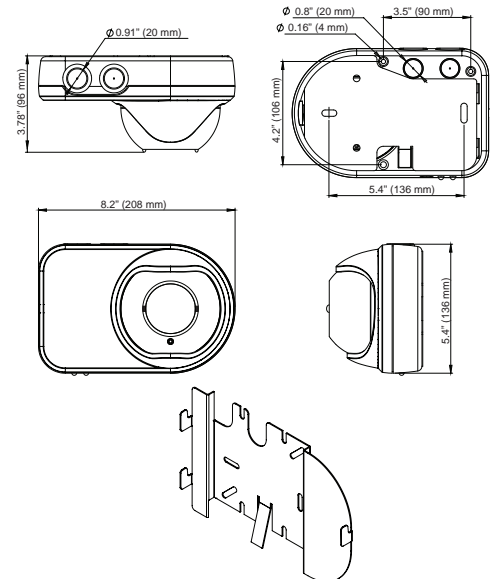

Specifications

Supply Voltage	20 to 30 VDC (24 VDC nominal)
Imager Maximum Current	17mA (one Emitter), 21mA (seven Emitters)* * When RTS151KIT/KEY is connected, the Maximum Current is +6mA.
Imager Current Consumption (Typical at 24 VDC)	Nominal (at 24 VDC): • 15mA (1 Emitter) • 19mA (7 Emitters) Peak during training mode: 31mA
Emitter Current Consumption	Wired Version (at 24 VDC): 350µA Std Power, 800µA High Power Battery Version (1.9 - 3.2 VDC): OSE-RBA Built-in Battery: • SP Version: 5-year battery life • HP Version: 3-year battery life <i>Battery life time only valid for use at room temperature.</i>
Field Wiring	Cable Gauge: 0.2 - 4mm ² (26-12 AWG)
Alarm Threshold Levels	Low - Highest sensitivity / earliest alarm: 20% (0.97 dB) Medium - Medium sensitivity: 35% (1.87 dB) High - Low sensitivity: 50% (3.01 dB) Highest - Lowest sensitivity, Industrial Mode: 65% (4.56 dB) <i>Do not use Heater nor Dust Rejection if OSI-90 is set at 65% sensitivity.</i>
Adjustment Angle	±60° (horizontal) ±15° (vertical)
Maximum Misalignment Angle	±2°
Dimensions (WHD)	Emitter / Imager: 8.19 in. x 5.35 in. x 3.78 in. (208 mm x 136 mm x 96 mm)
Operating Conditions*	Temperature: 14 °F to 131 °F (-10 °C to 55 °C)* Humidity: 10 to 95% RH (non-condensing) <i>Please consult your Xtralis office for operation outside these parameters.</i>
Storage Conditions (non-operational)	Humidity: Dry (<95%) Temperature: 0° to 85° C Must not be exposed to sunlight or other radiation sources.
IP Rating	IP 40 for Electronics IP 66 for Optics Enclosure
Status LEDs	Fire Alarm (Red) Trouble / Power (Bi-color Yellow / Green)
Event log	10,000 events (Imager firmware V4.0 or greater required)
Color	White, RAL9003

* Product UL listed for use from 32°F to 100°F (0°C to 37.8°C).

Ordering Information

Ordering Code	Description
OSI-10	Imager - 7° coverage
OSI-90	Imager - 80° coverage
OSE-SP-01	Emitter - Alkaline battery
OSE-SPW	Emitter - Standard Power, Wired
OSE-HP-01	Emitter - High power alkaline battery
OSE-HPW	Emitter - High Power, Wired
OSID-EHI	Imager environmental housing IP66
OSID-EHE	Emitter environmental housing IP66
OSE-ACF	Anti-condensation film for Emitters
OSEH-ACF	Anti-condensation film for OSID-EHE and OSID-EHI environmental housings
OSID-WG	Wire Guard
RTS151KIT	Imager Reset Station Surface Mount
RTS151KEY	Imager Reset Station Flush Mount
OSP-001	FTDI Cable 1.5 m
OSP-002	Laser Alignment tool
OSP-003	Acrylic test filter - pack of 10
OSP-003-200	Acrylic test filter - bulk pack (200 units)
OSE-RBA	Emitter - Spare alkaline battery pack
OSID-INST	OSID-DE Installation Kit

Approvals Compliance

Please refer to the Product Guide for details regarding compliant design, installation and commissioning.